

VEGAPULS 61

Radar sensor for continuous level measurement of liquids

The VEGAPULS 61 is a sensor for continuous level measurement of liquids under simple process conditions. Due to its simple and versatile mounting options, VEGAPULS 61 offers a truly cost-effective solution. The encapsulated antenna system ensures maintenance-free operation.



Exact measuring results



High plant availability



Maintenance-free operation

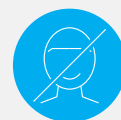

Non-contact measuring principle

Your benefit

- Maintenance-free operation thanks to non-contact measuring principle
- High plant availability, because wear and maintenance free
- Exact measuring results independent of process conditions

Function

Extremely short microwave pulses are emitted by the antenna system in the direction of the measured product, reflected by the product surface and received back again by the antenna system. The time from emission to reception of the signals is proportional to the level in the vessel. A special time stretching procedure allows reliable and precise measurement of the extremely short signal running times.

Materials

The wetted parts of the instrument are made of PVDF or PP. The process seal is made of FPM. You will find a complete overview of the available materials and seals in the "Configurator" at www.vega.com and "VEGA Tools".

Housing versions

The housings are available as double chamber version in plastic, stainlesssteel or aluminium. They are available in protection class IP 66/IP 67.

Electronics versions

The instruments are available in different electronics versions. Apart from 4 ... 20 mA/HART in two and four-wire version, there are also digital versions with Profibus PA, Foundation Fieldbus and Modbus protocols. Another HART version is available with integrated accumulator.

Approvals

The instruments are suitable for use in hazardous areas and are approved e.g. according to ATEX and IEC. The instruments also have various ship approvals such as e.g. GL, LRS or ABS. You can find detailed information at www.vega.com/downloads and "Approvals".

Technical data

Measuring range	up to 35 m (114.8 ft)
Deviation	±2 mm
Process fitting	thread G1½, 1½ NPT, mounting strap, compression flanges from DN 80, 3", adapter flanges from DN 100, 4"
Process pressure	-1 to +3 bar / -100 to +300 kPa (-14.5 to +43.5 psig)
Process temperature	-40 to +80 °C (-40 to +176 °F)
Ambient, storage and transport temperature	-40 to +70 °C (-40 to +158 °F)
Operating voltage	
• Version for low voltage	9.6 to 48 V DC, 20 to 42 V AC, 50/60 Hz
• Version for mains voltage	90 to 253 V AC, 50/60 Hz
SIL qualification	optionally up to SIL2

Operation

The adjustment of the instrument is carried out via the optional display and adjustment module PLICSCOM or via a PC with the adjustment software PACTware and corresponding DTM. Further adjustment options are possible via a HART Communicator as well as manufacturer-specific programs such as AMS or PDM.



Dimensions

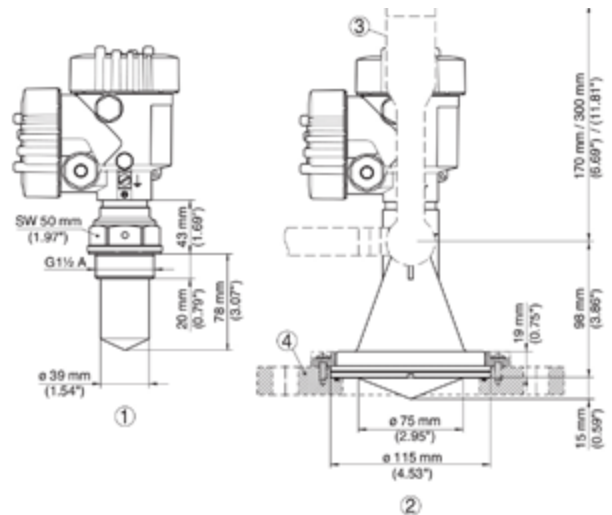

Dimensions VEGAPULS 61

- 1 Version with encapsulated antenna system
- 2 Version with plastic horn antenna
- 3 Mounting strap
- 4 Adapter flange